

玄豐電子有限公司

CYCLONE LIGHT ELECTRONICS CO., LTD.

TEL:886-2-2293-7117 (REP.) FAX:886-2-2293-7118(REP.)

規格承認書

APPROVED SHEET

CD-SXXXXXXXX

客戶名稱 / CUSTOMER NAME :

產品型號 / PRODUCT NUMBER :

客戶料號 / CUSTOMER' P/N :



CUSTOMER ENGINEERING DEPARTMENT	CYCLONE LIGHT ELECTRONICS CO., LTD. ENGINEERING DEPARTMENT
<hr/> (Authorized Signature)	<hr/>

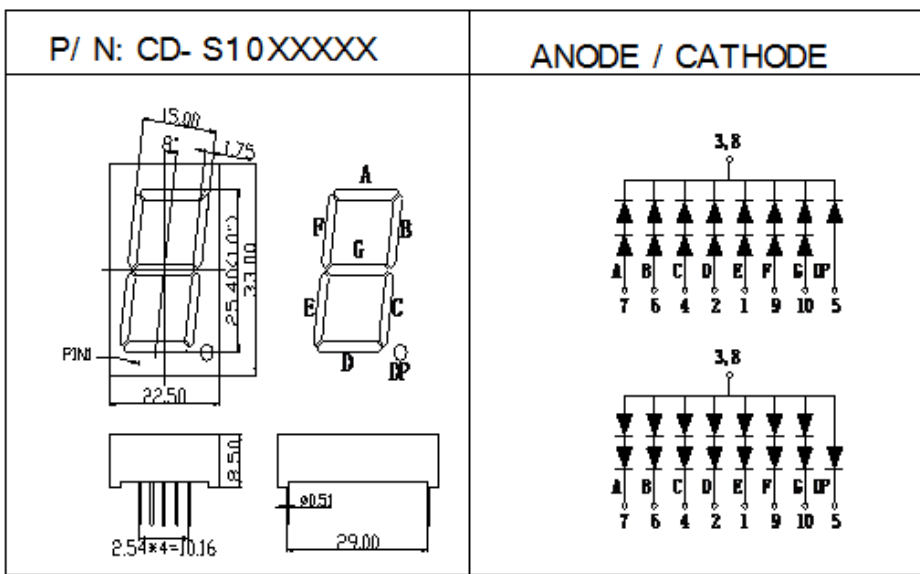
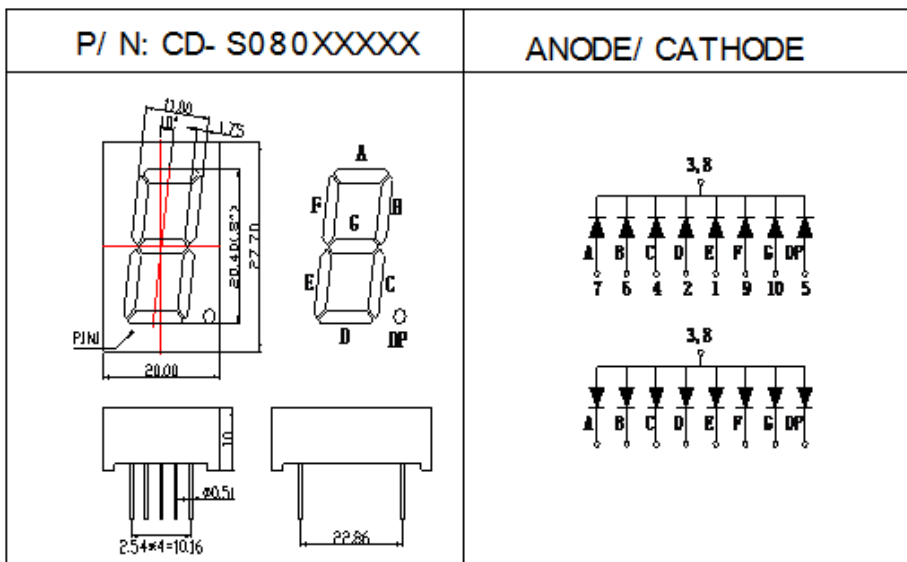
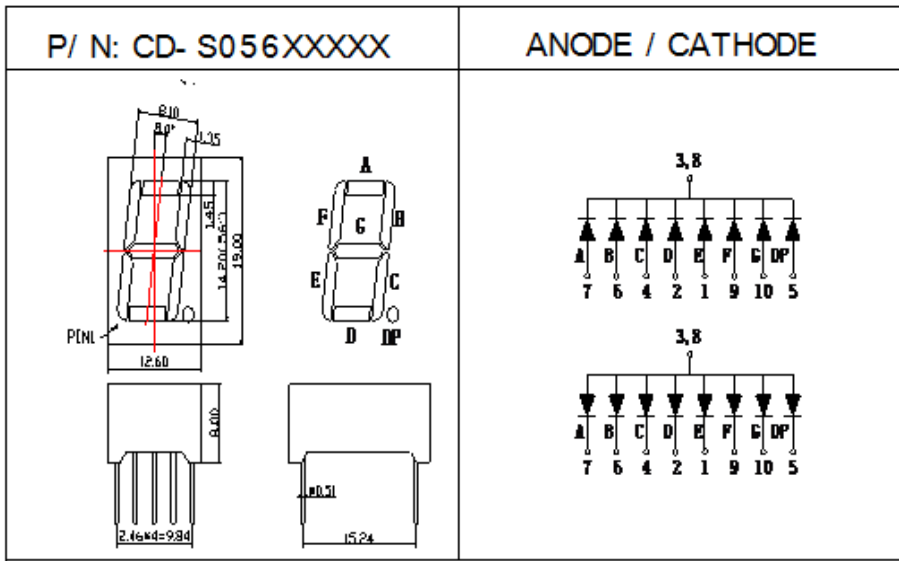

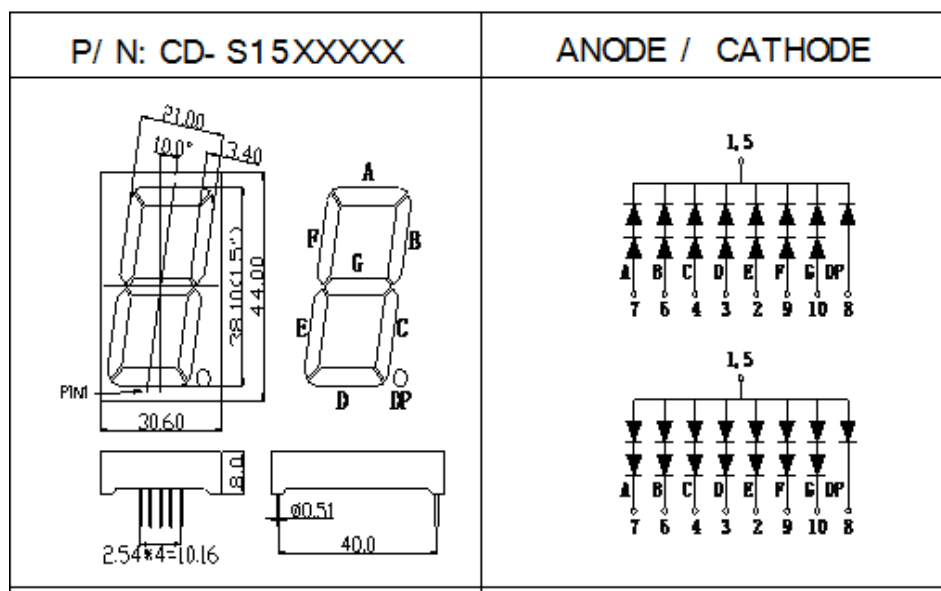
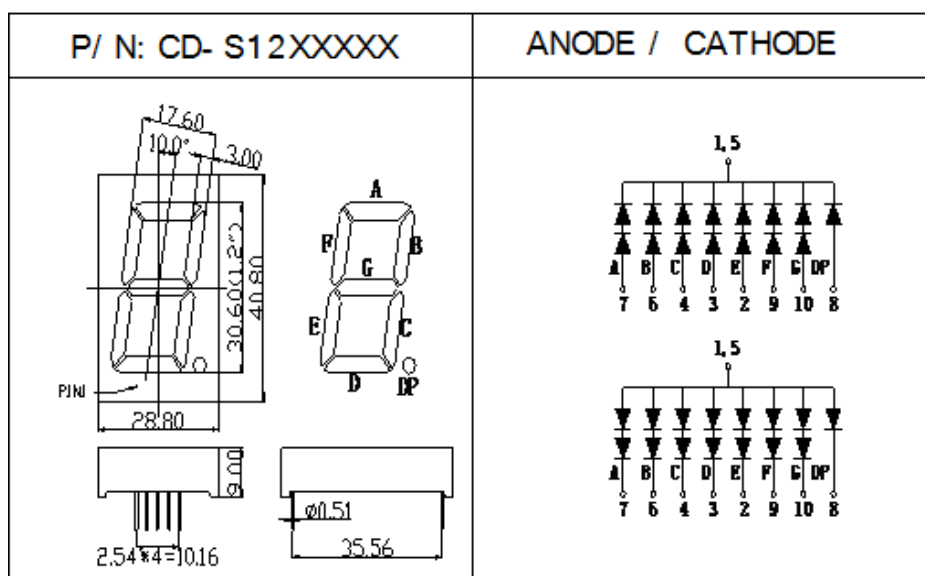

Notes :

1. Dimensions are in millimeters.
2. Tolerance is $\pm 0.25\text{mm}$ without noted.

2.ELECTRICAL / OPTICAL CHARACTERISITICS AT Ta = 25°C

PARAMETER	Forward Voltage		Reverse Current		Luminous Intensity	Peak Emission Wavelength	Power Dissipation
SYMBOL	VF		IR		IV	λ_p	PD
UNIT	V		uA		mcd	nm	mW
TEST	IF=20mA		VR=5V		IF=20mA	IF=20mA	IF=20mA
	TYP	MAX	TYP	MAX	TYP	MAX	TYP
CD-SXXXXXCRF	2	2.4	--	20	5	630	36
CD-SXXXXXYGF	2.2	2.6	--	20	5	571	44
CD-SXXXXXCYP	2.1	2.5	--	20	8.5	590	42
CD-SXXXXXTB	3.3	4	--	20	12	465	66
CD-SXXXXXTG	3.3	4	--	20	100	515	66
CD-SXXXXXBW	3.3	4	--	20	100	8000K	66

3 SURFACE COLOR

3.1 Black Face

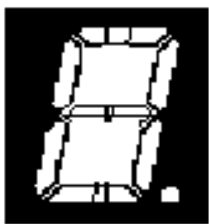

3.2 Gray Face

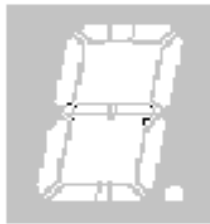

3.3 Red Face



Precautions For Use LED

1. Over-current-proof

Customer must apply resistors for protection; otherwise slight voltage shift will cause big current change (Burn out will happen).

2. Storage

2.1 Do not open moisture proof bag before the products are ready to use.

2.2 Before opening the package: The LEDs should be kept at 30°C or less and 90%RH or less.

2.3 After opening the package: The LED's floor life is 168 Hrs under 30°C or less and 60% RH or less. If unused

LEDs remain, it should be stored in moisture proof packages.

2.4 If the moisture absorbent material (silica gel) has faded away or the LEDs have exceeded the storage time, baking treatment should be performed using the following conditions.

Baking treatment: 60±5°C for 24 hours.

3. Soldering Condition

Pb-free solder temperature profile

