

1. Package Size: 4.7mm Round / HOUSING

2. Color and Luminous Intensity:

Part No.	Emitted Color	Resin Color	Luminous Intensity (mcd)		Test Current
			MIN.	TYP.	
CL-H4775HRD	Red	DIFFUSED	20	50	20mA
CL-H4775HAD	Amber	DIFFUSED	20	50	
CL-H4775HGD	Yellow Green	DIFFUSED	10	20	
CL-H4775HYD	Yellow	DIFFUSED	20	50	
CL-H4775HTGD	Ultra Green	DIFFUSED	130	150	
CL-H4775HBD	Blue	DIFFUSED	50	80	
CL-H4775HWD	White	DIFFUSED	100	180	

※1 Luminous intensity : 1chips

3. Absolute Maximum Ratings:

Item	Symbol	Absolute Maximum Ratings							Unit	
		CRF	AMB	YGF	CYF	TG	TB	BW		
Power Dissipation	P_d	70	70	70	70	70	70	70	mW	
Forward Current	I_F	20	20	20	20	20	20	30	mA	
Pulse Forward Current [※]	I_{FRM}	60	60	60	60	60	60	60	mA	
Reverse Voltage	V_R	5	5	5	5	5	5	5	V	
Operating Temperature	T_{opr}	- 40 ~ + 85								°C
Storage Temperature	T_{stg}	- 40 ~ + 85								°C

※2 Power Dissipation : 1chips

※3 I_{FRM} Measurement condition : Pulse Width \leq 2ms, Duty \leq 1/5

4. Electro-Optical Characteristics

Item	Conditions	Symbol	Characteristics							Unit	
				CRF	AMB	YGF	CYF	TG	TB		BW
Forward Voltage	IF=20mA	V_F	TYP.	1.8	1.8	1.8	1.8	2.8	2.8	2.8	V
			MAX.	2.3	2.5	2.5	2.5	3.5	3.5	3.5	
Dominant Wavelength	IF=20mA	λ_d	TYP.	625	605	570	590	525	460	8000k	nm

PACKAGE DIMENSIONS

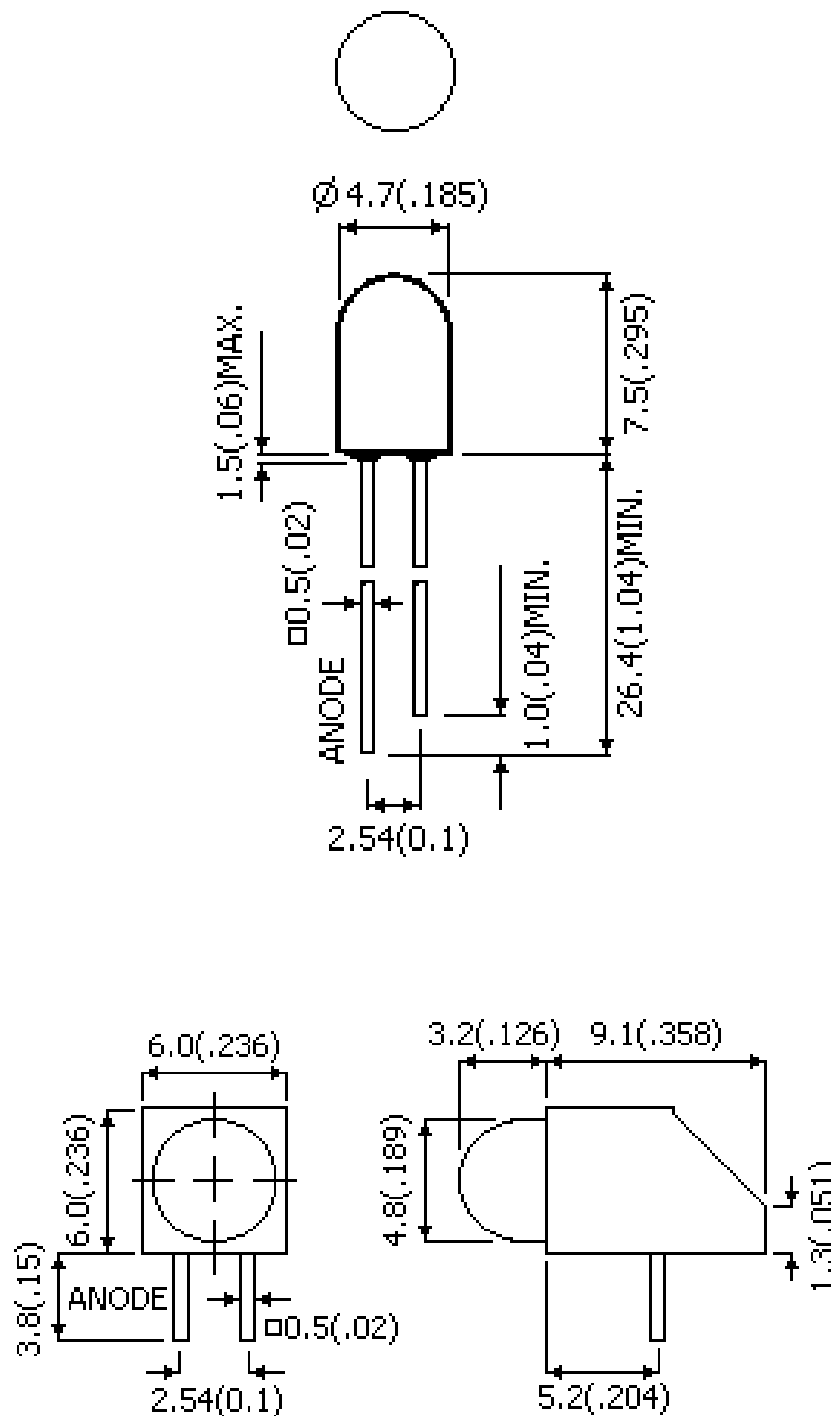

Notes :

1. Dimensions are in millimeters.
2. Tolerance is $\pm 0.25\text{mm}$ without noted.

Precautions For Use LED

1. Over-current-proof

Customer must apply resistors for protection; otherwise slight voltage shift will cause big current change (Burn out will happen).

2. Storage

2.1 Do not open moisture proof bag before the products are ready to use.

2.2 Before opening the package: The LEDs should be kept at 30°C or less and 90%RH or less.

2.3 After opening the package: The LED's floor life is 168 Hrs under 30°C or less and 60% RH or less. If unused

LEDs remain, it should be stored in moisture proof packages.

2.4 If the moisture absorbent material (silica gel) has faded away or the LEDs have exceeded the storage time, baking treatment should be performed using the following conditions.

Baking treatment: 60±5°C for 24 hours.

3. Soldering Condition

Pb-free solder temperature profile

