

玄豐電子有限公司

CYCLONE LIGHT ELECTRONICS CO., LTD.

TEL:886-2-2293-7117 (REP.) FAX:886-2-2293-7118(REP.)

規格承認書

APPROVED SHEET

Part No:CL-LV5270XXXX

客戶名稱 / CUSTOMER NAME :

產品型號 / PRODUCT NUMBER :

客戶料號 / CUSTOMER P/N :



CUSTOMER ENGINEERING DEPARTMENT	CYCLONE LIGHT ELECTRONICS CO., LTD. ENGINEERING DEPARTMENT
<hr/> (Authorized Signature)	<hr/>

1. Package Size: 5.2mm Round Oval Type LED Lamp

2. Color and Luminous Intensity:

Part No.	Emitted Color	LENS Color	Luminous Intensity (mcd)		Test Current
			MIN.	TYP.	
CL-LV5270CRFC	Red	CLEAR	1200	1500	20mA
CL- LV5270AMBC	Amber	CLEAR	1200	1400	
CL- LV5270YGF	Yellow Green	CLEAR	100	200	
CL- LV5270CYFC	Yellow	CLEAR	1200	1400	
CL -LV5270TGC	Ultra Green	CLEAR	5000	7500	
CL- LV5270TBC	Blue	CLEAR	800	1500	
CL- LV5270BWC	White	CLEAR	5000	8000	

※1 Luminous intensity : 1chips

3. Absolute Maximum Ratings:

Item	Symbol	Absolute Maximum Ratings							Unit
		CRF	AMB	YGF	CYF	TG	TB	BW	
Power Dissipation	P_d	70	70	70	70	70	70	70	mW
Forward Current	I_F	30	30	30	30	30	30	30	mA
Pulse Forward Current [※]	I_{FRM}	60	60	60	60	60	60	60	mA
Reverse Voltage	V_R	5	5	5	5	5	5	5	V
Operating Temperature	T_{opr}	- 40 ~ + 85							°C
Storage Temperature	T_{stg}	- 40 ~ + 85							°C

※2 Power Dissipation : 1chips

※3 I_{FRM} Measurement condition : Pulse Width \leq 2ms, Duty \leq 1/5

4. Electro-Optical Characteristics

Item	Conditions	Symbol	Characteristics							Unit	
				CRF	AMB	YGF	CYF	TG	TB		BW
Forward Voltage	IF=20mA	V_F	TYP.	1.8	1.8	1.8	1.8	2.8	2.8	2.8	V
			MAX	2.3	2.5	2.5	2.5	3.5	3.5	3.5	
Dominant Wavelength	IF=20mA	λ_d	TYP.	625	605	570	590	525	460	8000k	nm
Viewing Angle	IF=20mA	2θ 1/2	TYP	X:110 Y:70	X:110 Y:70	X:110 Y:70	X:110 Y:70	X:110 Y:70	X:110 Y:70	X:110 Y:70	deg

PACKAGE DIMENSIONS

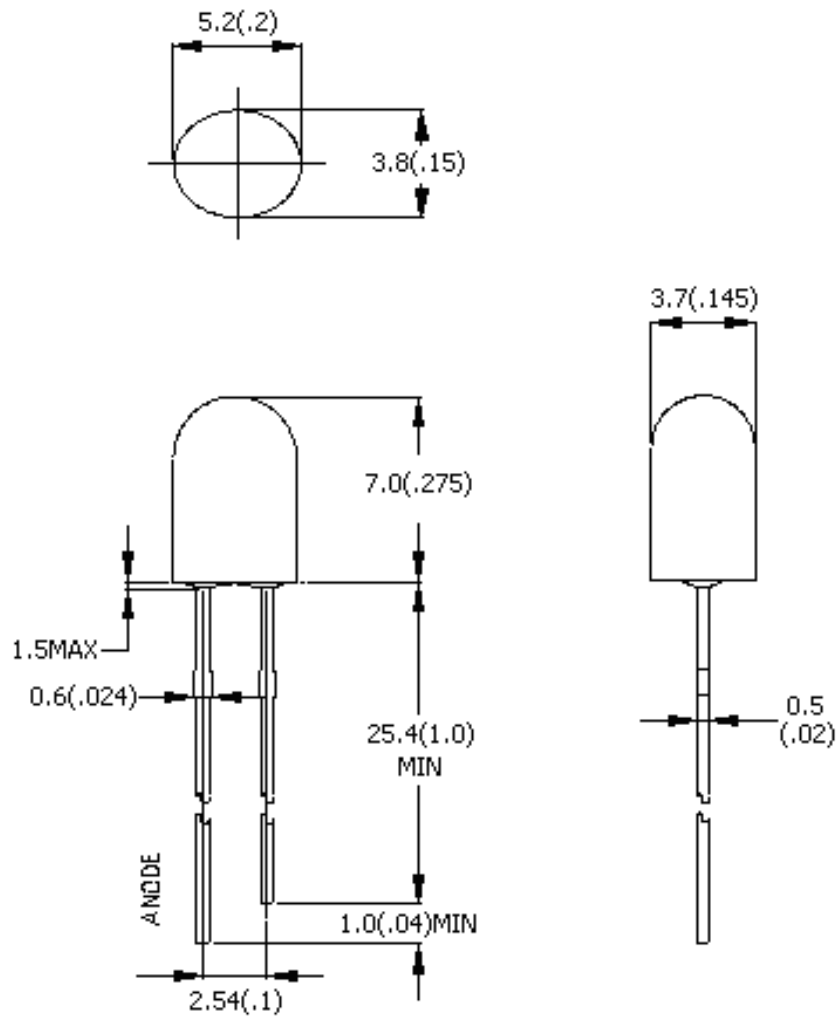

Notes :

1. Dimensions are in millimeters.
2. Tolerance is ± 0.25 mm without noted.

Precautions For Use LED

1. Over-current-proof

Customer must apply resistors for protection; otherwise slight voltage shift will cause big current change (Burn out will happen).

2. Storage

2.1 Do not open moisture proof bag before the products are ready to use.

2.2 Before opening the package: The LEDs should be kept at 30°C or less and 90%RH or less.

2.3 After opening the package: The LED's floor life is 168 Hrs under 30°C or less and 60% RH or less. If unused

LEDs remain, it should be stored in moisture proof packages.

2.4 If the moisture absorbent material (silica gel) has faded away or the LEDs have exceeded the storage time, baking treatment should be performed using the following conditions.

Baking treatment: 60±5°C for 24 hours.

3. Soldering Condition

Pb-free solder temperature profile

