

1. Package Size: 2.0mm*1.25*0.8H

2. Color:

COLOR	
Emitted	Lens
PURPLE	CLEAR

3. Absolute Maximum Ratings:

Parameter	Symbol	Ratings	UNIT
Forward Current	IF	30	mA
Power Dissipation	PD	75	mW
Peak Forward Current Duty (1/10@0.1ms Pulse Width)	IFP	70	mA
Reverse Voltage	VR	5	V
Storage Temperature	Tstg	-40~+85	°C
Operating Temperature	Topr	-40~+85	°C

※2 Power Dissipation : 1chips

※3 I_{FRM} Measurement condition : Pulse Width ≤ 2ms, Duty ≤ 1/5

4. Electro-Optical Characteristics

Parameter	Symbol	Min.	Typ.	Max.	UNIT	CONDITION
Peak Wavelength	λ_{peak}	----	400	----	nm	IF=20mA
Dominant Wavelength	λ_D	----	395	----	nm	IF=20mA
Spectral Line Half-Width	$\Delta\lambda_{1/2}$	----	20	----	nm	IF=20mA
Forward Voltage	VF	2.8	---	3.6	V	IF=20mA
Reverse Current	IR	----	----	10	uA	VR=5V
Luminous Intensity	Iv	----	10	----	Mcd	IF=20mA
Viewing Angle	2θ 1/2	----	120	----	deg	IF=20mA

PACKAGE DIMENSIONS

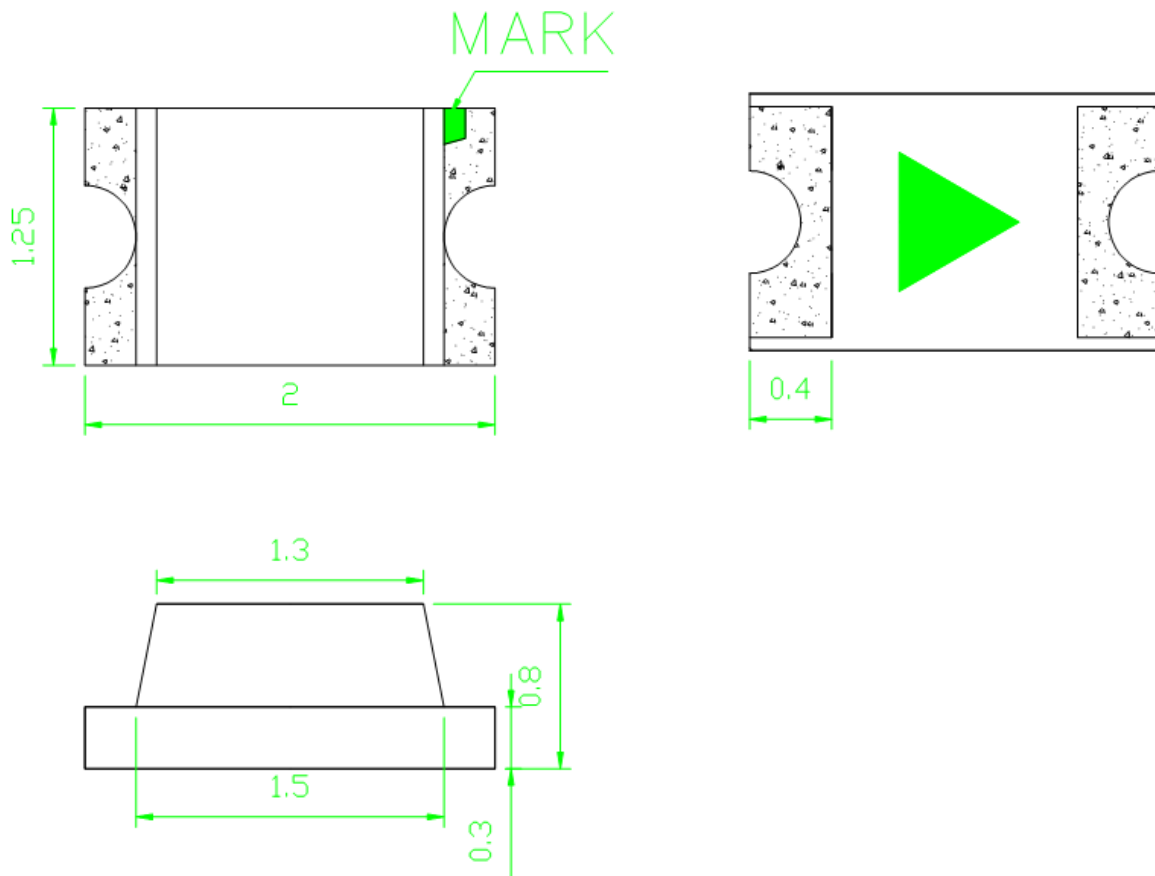

Notes :

1. Dimensions are in millimeters.
2. Tolerance is ± 0.25 mm without noted.

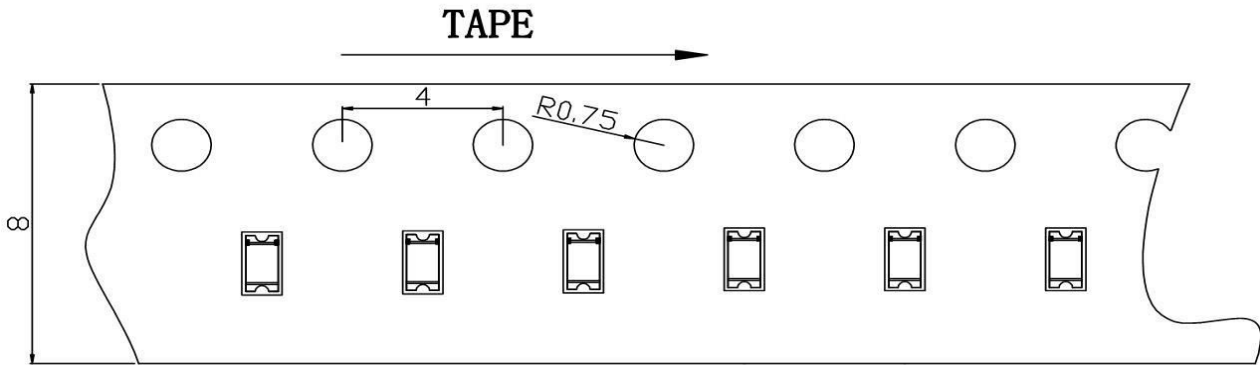

Carrier Type Dimensions

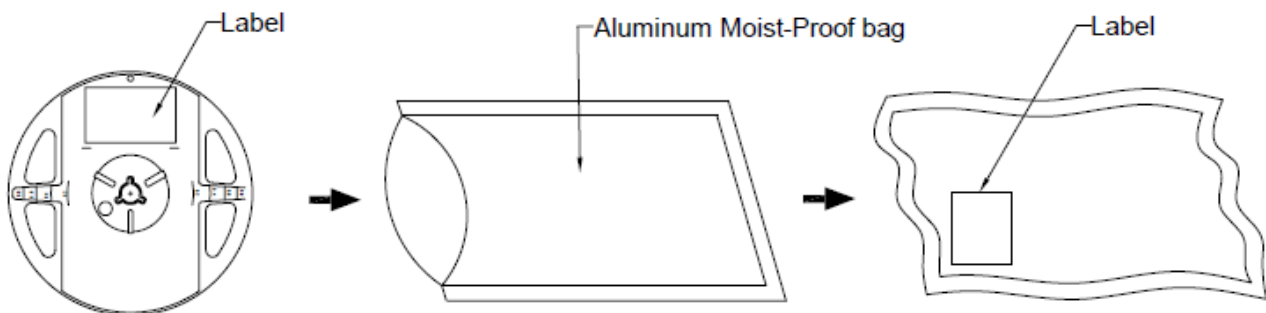

Packing Specifications



Cyclonelight

<p>P/N:CL-XXXXXXXXXX</p>  <p>QTY:4000 PCS</p>  <p>LOT NO:XXXXXXXXXX</p> 	<div style="border: 1px solid black; padding: 2px; display: inline-block;">ROHS</div> <p>HUE:XXX CAT:XXX REF:XXX</p>
--	---

Precautions For Use LED

1. Over-current-proof

Customer must apply resistors for protection; otherwise slight voltage shift will cause big current change (Burn out will happen).

2. Storage

2.1 Do not open moisture proof bag before the products are ready to use.

2.2 Before opening the package: The LEDs should be kept at 30°C or less and 90%RH or less.

2.3 After opening the package: The LED's floor life is 168 Hrs under 30°C or less and 60% RH or less. If unused

LEDs remain, it should be stored in moisture proof packages.

2.4 If the moisture absorbent material (silica gel) has faded away or the LEDs have exceeded the storage time, baking treatment should be performed using the following conditions.

Baking treatment: 60±5°C for 24 hours.

3. Soldering Condition

Pb-free solder temperature profile

